



**FSM Frankenberger
GmbH & Co. KG**

Equipment for Water
and Waste Water
Inlet Works



Vertical
Screw Screen



FSM Frankenberger GmbH & Co. KG
Vor dem Hohen Stein 1 · D-35415 Pohlheim/Garbenteich
Tel. +49 (0) 06404-9194-0 · Fax +49 (0) 06404-9194-91
info@fsm-umwelt.de · www.fsm-umwelt.de

FSM Vertical Screw Screen

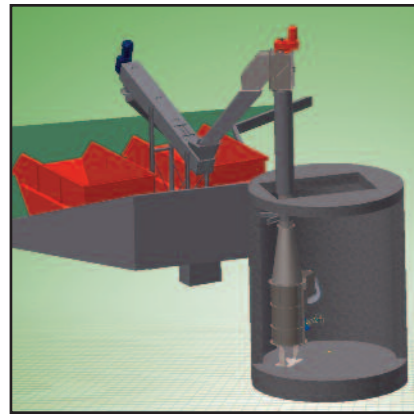

Functional principle:

The waste water flows through a perforated basket. The installation angle is 90°. The basket is fixed and cleaned by a rotated screw with a cleaning brush. The screening is transported, washed and compacted by one screw. This design guaranteed that no screening can pass the screen by "carryover" effect.

The screw is designed in the dewatering zone with shaft to reduce the wear and prevent a blockage.

Perforation for the screen basket is from 2 mm up to 10 mm. The cleaning of the basket is performed by a brush. The drive is realized by a gear motor at the top.

Features:

- High reliability through robust construction
- No additional cleaning systems
- Screenings conveyed positively to the discharge point
- Excellent cost/performance ratio
- Low maintenance costs
- Suitable for outdoor sites / operation in winter
- Easily adapted to suit changed operating conditions
- Machine completely hygienically Encapsulated



The FSM Vertical Screw Screen meets the most demanding specifications.

The FSM Vertical Screw Screen was developed to deal with particular problems associated with sewage pretreatment plant.

Parallel to the increasing demands of users, FSM introduced modifications to the basic design. These have resulted in an optimum product for the preliminary treatment of waste water - providing a protection for pumping stations.

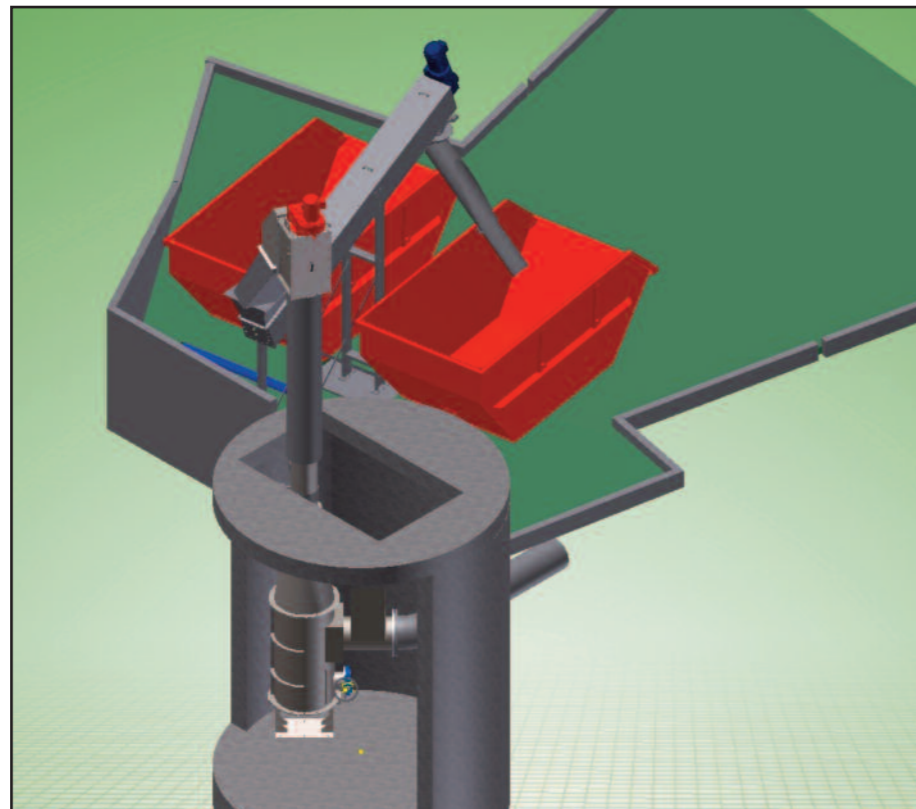

Applications in municipal and industrial clarification plant

- waste water pre-treatment / fine screening
- sludge screening / secondary sludge
- sludge screening / primary sludge
- fecal matter reception and treatment

Industrial applications

- textile and textile finishing industry - preliminary clarification of total waste water
- meat, fish and poultry processing / slaughterhouses - preliminary clarification of total waste water
- sugar industry - preliminary clarification of total waste water
- fruit and vegetable processing - preliminary clarification of total waste water
- breweries - preliminary clarification of total waste water

Dimensions:

Screen width for installation	200 to 600 mm
Perforation	2 - 10 mm, other sizes on request
Installation angle	90°, other angles on request

Material/make:

machine frame	stainless steel SS304 or SS316, other materials on request
filter element	stainless steel SS304 or SS316, other materials on request
drives	geared motors, make SEW